

Maxillary Skeletal Expander

MSE

Maxillary Skeletal Expander

Guide Book Vol.1

Invented by Prof. Won Moon

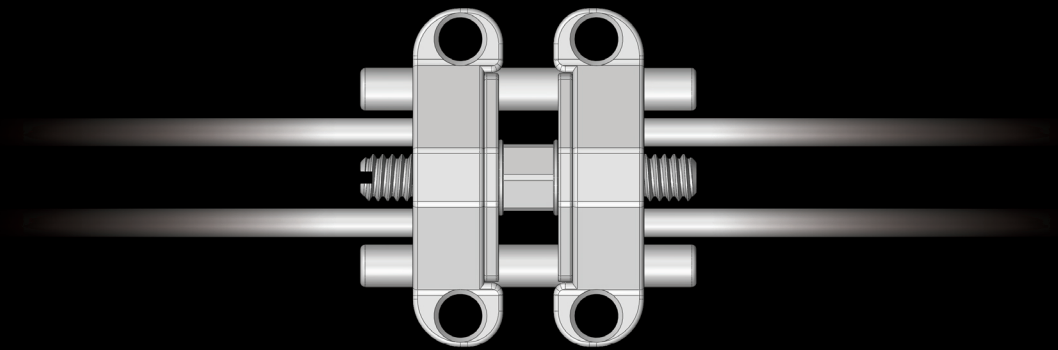

The First Innovative Expander System in the world



OFFICE 11917 Front St. Norwalk, CA 90650 WEBSITE www.uniortholab.com
TEL. 877 - 771 - 0770 E-MAIL customerservice@uniortholab.com



OFFICE 11917 Front St. Norwalk, CA 90650 WEBSITE www.usortho.com
TEL. 866 - 928 - 4404 E-MAIL sales@usortho.com

BIOMATERIALS
KOREA Orthodontics &
Osteosynthesis

Biomaterials America, Inc.
19700 S. Vermont Ave. Suite 200 Torrance, CA 90502
TEL : +1-213-618-8725

Biomaterials Korea, Inc.
#402, 11 Dongsan-ro 41-gil, Yeongdeungpo-gu, Seoul, 07217 Korea
TEL : +82-2-2088-4921 FAX : +82-70-4337-4555



FaceBook



User
Group



Youtube

www.biomk.com
www.moonmse.com



UNIVERSAL LAB®



US ORTHODONTIC PRODUCTS®

Inventor



Prof. Won Moon, DMD, MS

"The Maxillary Skeletal Expander (M.S.E) can effect both dental and skeletal expansion. The adverse clinical consequences of RPE and SARPE in high-angle cases will be solved by M.S.E. Also, many patients who requiring maxillary expansion often have narrow nasal airways, and positive changes in nasal airway with application of M.S.E. are common."

Dr. Won Moon is the Founder of the Moon Principles Institute ("the MoonLab") and a Co-founder of BioTech Innovation. He served as the Thomas R. Bales Endowed Chair in Orthodontics for the orthodontic residency program at UCLA School of Dentistry (2013-2020), and he currently holds two academic positions: Full-Professorship at Ajou University, and Adjunct Professorship at Forsyth Institute. He has been a Diplomate of the American Board of Orthodontics since 2002. He completed his dental education at Harvard and orthodontic education at UCLA. He studied mathematics prior to dentistry, and his research topics include 3D image analysis utilizing surface mapping functions and Elliptical Fourier's Descriptors, Genomewide Association Study of Craniofacial Phenotypes, Finite Element Model (FEM) Development and Simulation, Applications of 3D Printing in Orthodontics, Orthopedic Correction, Airway Changes with Orthopedic Corrections, Accelerated Tooth Movement, Micro-implant (MI) Design study, Digital Workflow, and Aligner System Development.

His work has been published in various journals, not necessarily limited to orthodontics because of his physical science background, and he is a co-author of six textbooks. He has presented these findings in 37 countries, totaling over 450 presentations. He received multiple research grants during his tenure at UCLA, including the Groundbreaking Research Project Grant Award in 2014. Besides the numerous research and presentation awards over the years, he has received the "Faculty of the Year Award" more times than anyone at UCLA Orthodontic Program, and he was the recipient of the "Lifetime Achievement and Faculty Dedication/Excellence Award" in 2019. His current focus has been establishing protocols for orthopedic corrections with MI, improving the airway for patients with nasal obstruction, creating virtual patients utilizing image analysis and FEM, and developing a novel Moon Aligner System.

His interest in mid-facial expansion began in 2004 as micro-implant became available in the USA, and he is responsible for developing Maxillary Skeletal Expander (MSE), a unique micro-implant assisted rapid palatal expander (MARPE). He has been active in advocating non-surgical skeletal expansion in both children and adult patients, especially for those who may suffer from airway restrictions. His presentation in MSE has been widely accepted internationally and numerous peer-reviewed publications are available.

Article



Clinical Cases

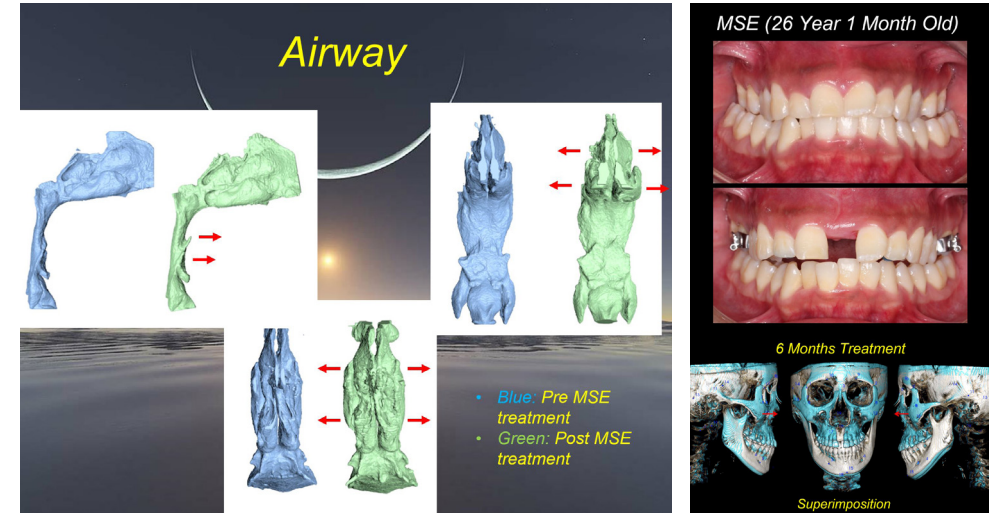

Activation Protocol

Caution : There could be situation when the hexagonal nut is not able to turn by the activation key
In this case, stop activation for max 3 weeks for bone regeneration

MSE I

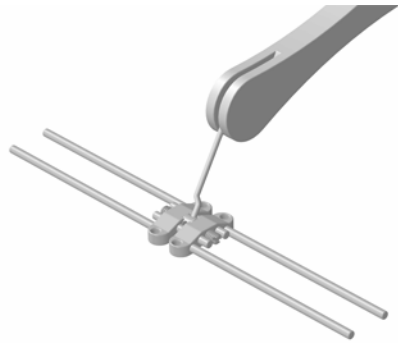

4 Turns = 0.8mm (1 revolution)
ex) MSE - 8 means to expand 8mm, Max. 40 turns

Early teens	3X / week (0.60mm / week)
Late teens	1 X / day (0.20mm / day)
Early to Mid-20's	2~3X / day (0.40~0.60mm / day)
Older	Min. 2~3X / day, assistance PRN
After Diastema	1X / day (0.20mm / day)

MSE II

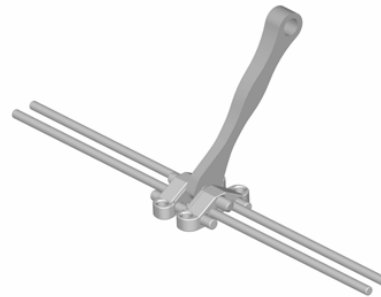

6 Turns = 0.8mm (1 revolution)
ex) MSE II - 12 means to expand 12mm, Max. 90 turns

Early teens	6X / week (0.80mm / week)
Late teens	2X / day (0.27mm / day)
Early to Mid-20's	4~6X / day (0.53~0.80mm / day)
Older	Min. 4~6X / day
After Diastema	2X / day (0.27mm / day)

The main difference between The MSE and Others

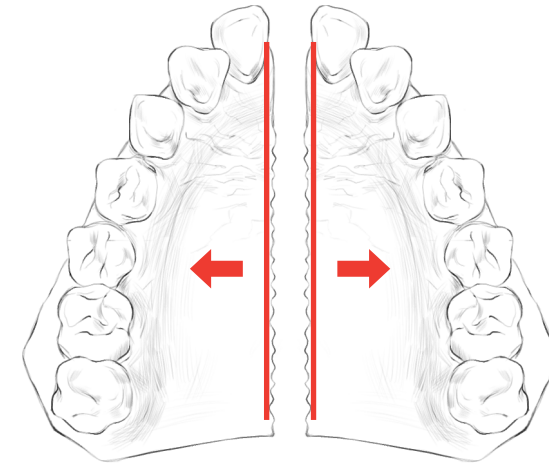

MSE

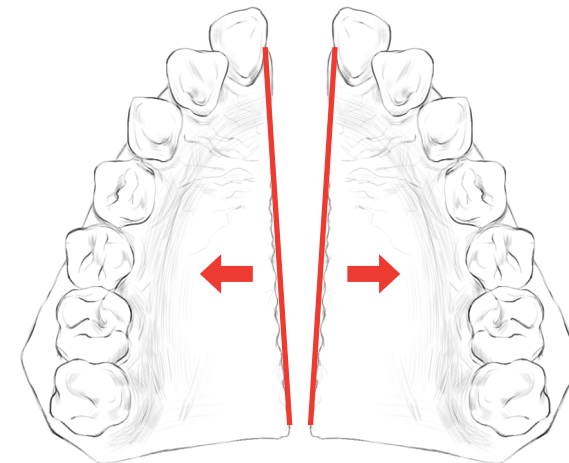

Others

Components

Starter kit

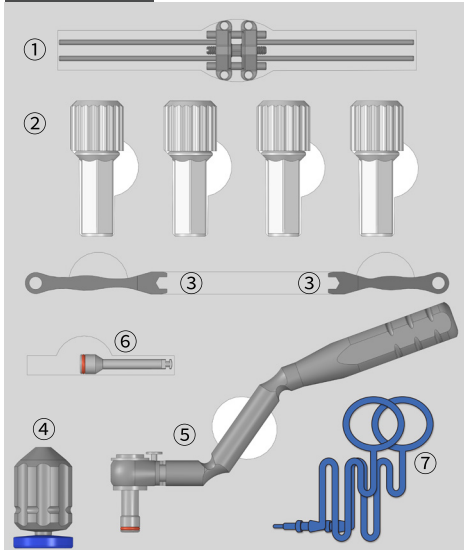

Refill kit

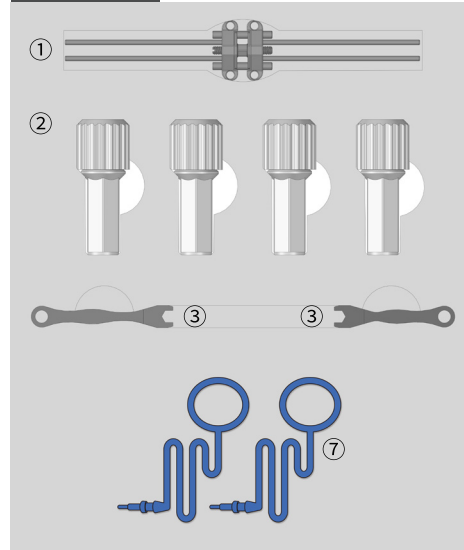

Components

- ① **MSE Expander** (Available expansion sizes : 8mm, 10mm & 12mm)
Choose an expander size according to a width of patient's palatal vault
- ② **Micro Implant(M.I)** (Ø 1.8mm X 11mm & 13mm Lengths are available)
Choose M.I length according to the thickness of patient's palatal bone
*For MSE type 1, M.I is Ø 1.5mm and for MSE type 2, M.I is Ø 1.8mm
- ③ **2 Activation Keys (1 Short & 1 Long)**
- ④ **Mini Hand Driver**
Use with initial insertion of M.I placement
The best way is to use Mini Hand Driver for initial
- ⑤ **Ratchet Wrench Driver**
Inserting and Removing M.I
- ⑥ **Short Engine Blade (Shaft)**
Attach to Mini Hand Driver
- ⑦ **Safety Leashes**
With ③ activation key

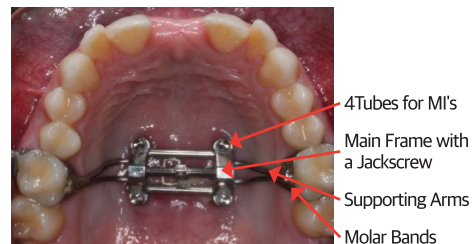

Placing M.I (Micro Implant)

Bi-Cortical process

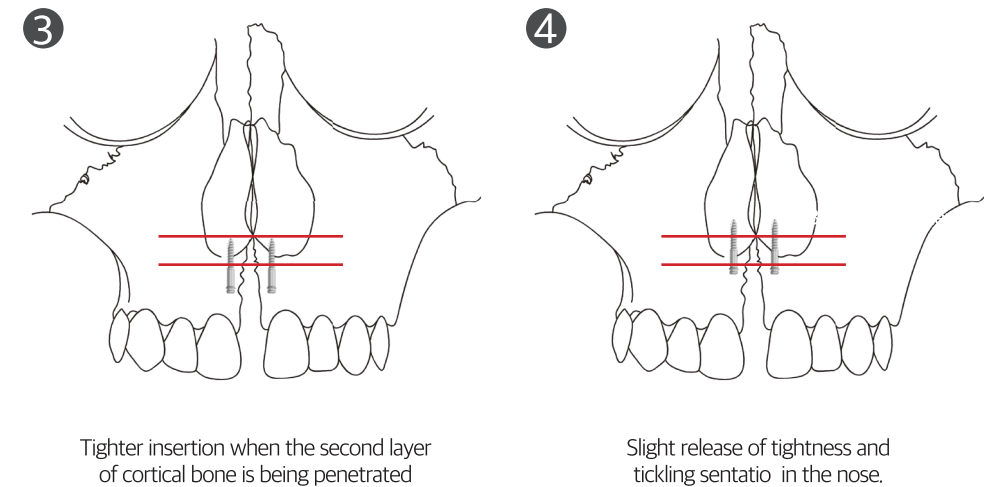
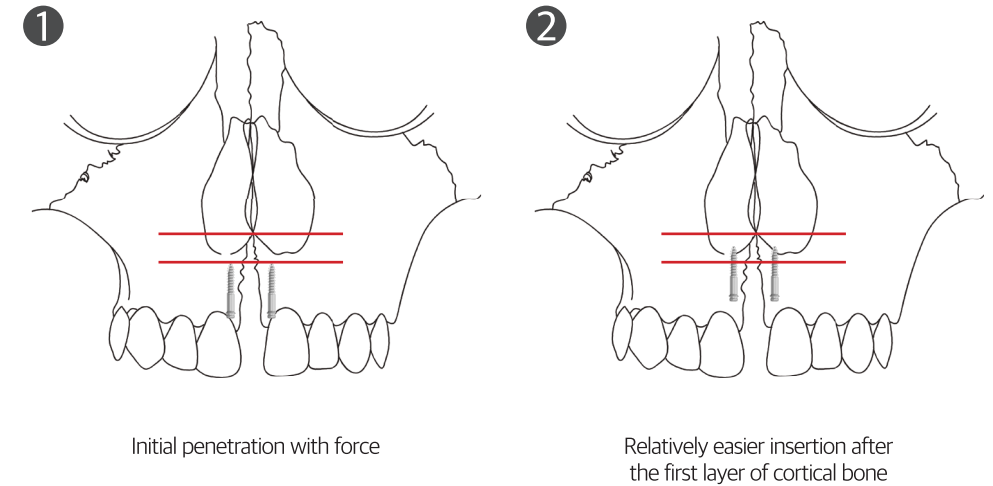

Placing M.I (Micro Implant)

1. Vertical Insertion

After an expander placement, Insert M.I
When inserting M.I, make sure they are placed vertically with proper insertion guidelines. (1-2-3-4)

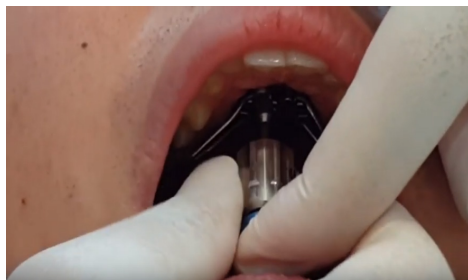
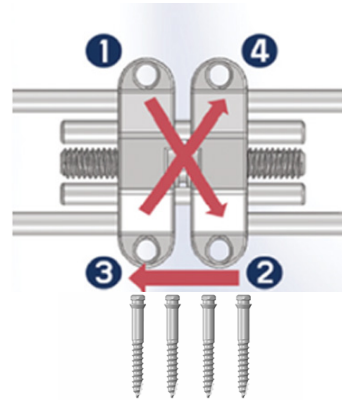

* [Manual Driver]_MHD + SEB

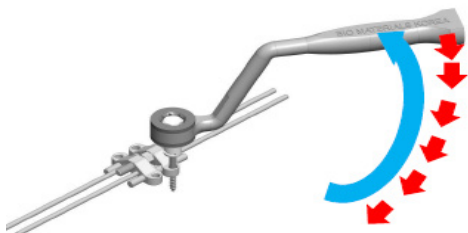

* [Manual Driver]_RW

It is important to insert M.I by applying force intermittently

2. Can I use a Motor Driver?

The inventor recommends to use the manual driver for placing M.I Because You can feel insertion torque and Bi-Cortical engagement as well

If you use motor driver, You can't feel insertion torque and bi-cortical engagement

Increasing high TQ level

Please don't insert the TAD too tightly because MSE body will be bent by strong pressures or forces

How to use Components

Mini Hand Driver + Short Engine Blade

- MHD and SEB
- Insert a blade into the mini hand driver hole
- Rotate the Blade until going through the MHD
- Place M.I same as a picture
- To separate the SEB and MHD, Press the blue button on the MHD

Ratchet Wrenches

Max. Insertion Torque : 80Ncm

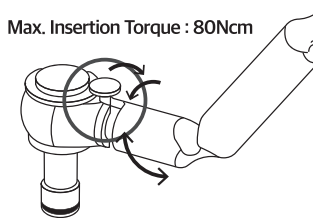

The button on the Top :
Locking direction

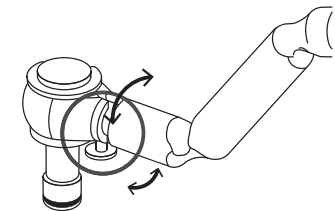

The button on the bottom :
Releasing direction

Safety Leash + Activation Key



Activation Key & Safety Leashes

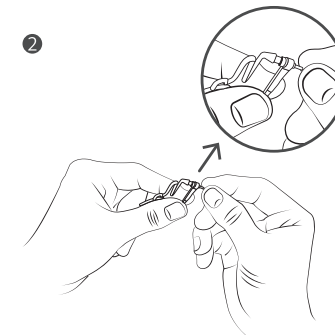
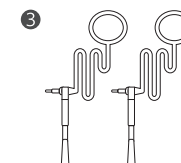

Pass through the key hole

Overview Process

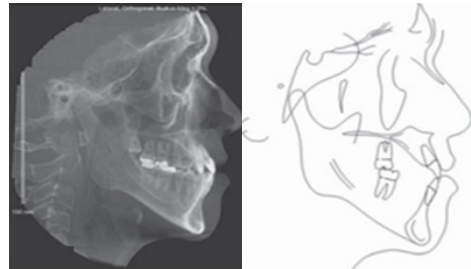

1 Take 1:1 Cephalo

To measure thickness of palatal bone and determine the proper length of M.I

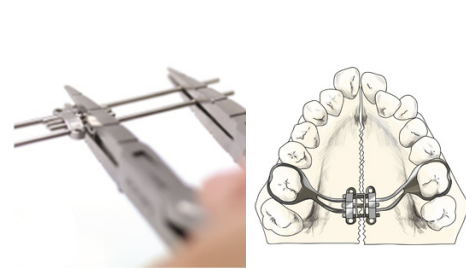

2 Lab work

Posterior position Weld to 6th teeth molar band

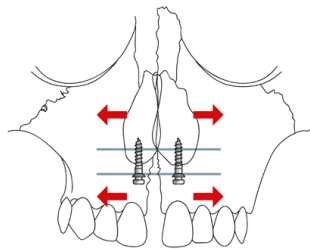

3 Insertion M.I

Bi-cortical Engagement
Vertical insertion
Use RW Driver and Mini driver

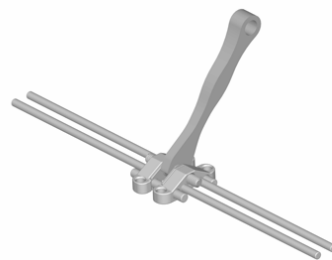

4 Activation protocol

6 Turns \approx 0.8mm (1 revolution)
ex) MSE II - 12 means to expand 12mm, Max. 90 turns

Lab Works

Fabrication 3

Place for suture line

1) MSE be placed as suture line

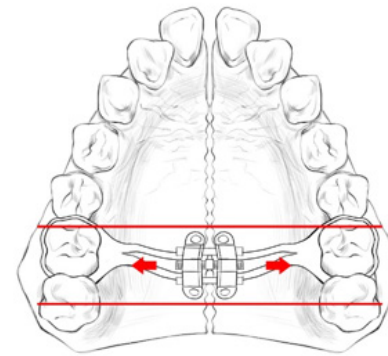

(o)

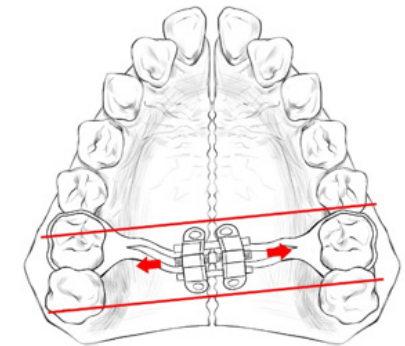

(x)

2) If suture is not vertical line, MSE needed to be additional expansion should place with suture line.

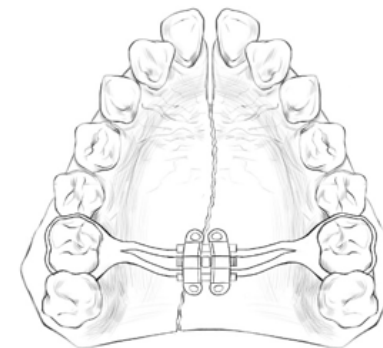

(x)

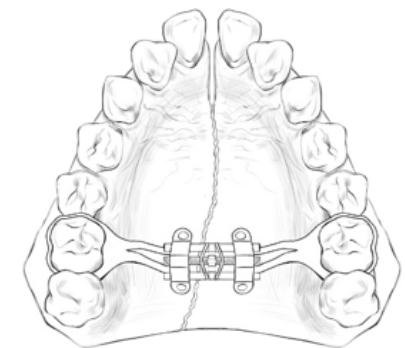

(o)

Lab Works

Fabrication 2

This process is one of the most important procedures to be success incorporate Bi-Cortical engagement & splitting of the suture

Proper MSE lab fabrication required : (Refer FAQ)

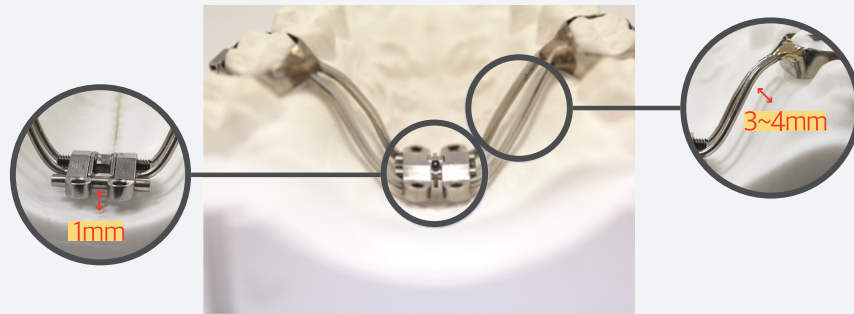

Less than 1mm space between palatal vault and the expander

Keep at least 3mm space between supporting arms and soft tissue in order to prevent tissue impingement

Soldered arms to the molar bands are intended as a guide for proper MSE placement

Even if the Mid-Palatal suture line is not in the middle, MSE must be placed vertically from the Mid-Line of the maxilla

Analysis

1. Deciding an expander size of MSE by the width of maxillary arch

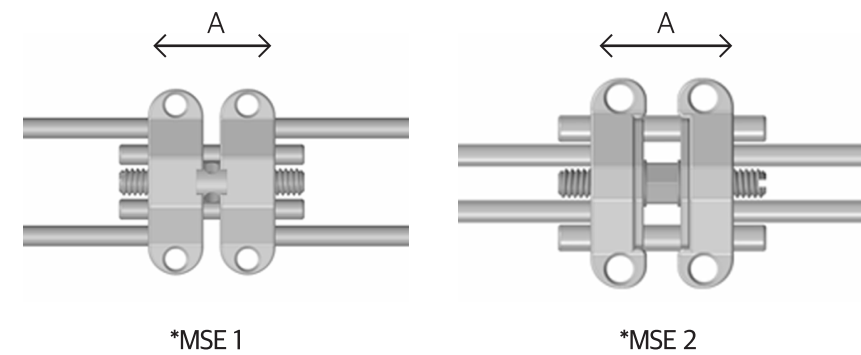
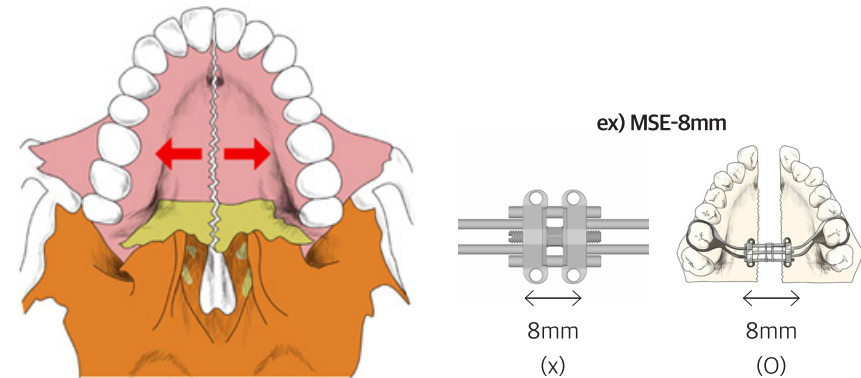

MSE	8mm	10mm	12mm
Type1 (A)	13.4mm	15.4mm	17.4mm
Type2 (A)	14.1mm	16.1mm	18.1mm

*The expansion size does not mean the width of the MSE (Please see the dimension above)

Analysis

2. To measure thickness of palatal bone and determine the proper length of M.I

*To be bi-cortical, The Inventor recommends to 11mm Length M.I, but if a mid palatal is narrow, 13mm M.I can be used.

MSE Mini Implant

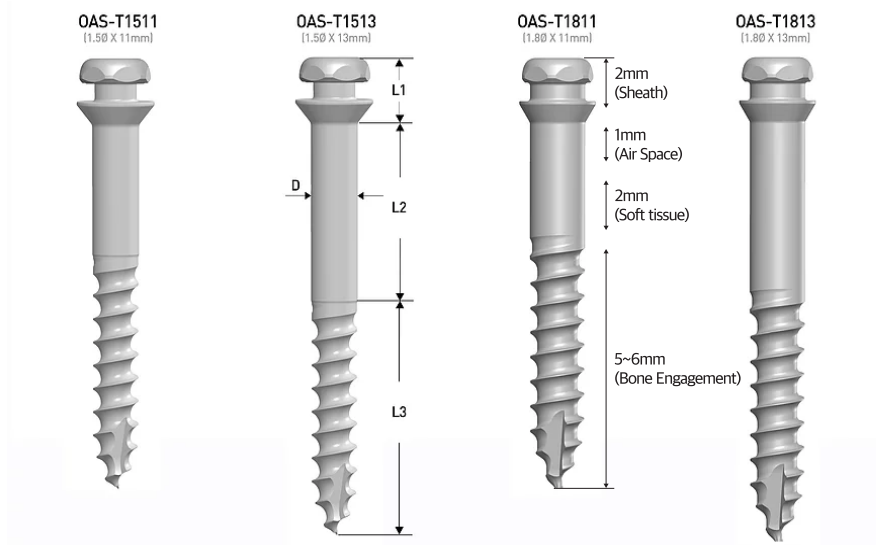

Type	Model	D (Diameter)	L1 (Head part)	L2 (Non-thread part)	L3 (Thread part)
MSE- I	OAS-T1511	1.50	2.10	4.00	7.00
	OAS-T1513	1.50	2.10	6.00	7.00
MSE- II	OAS-T1811	1.80	2.10	4.00	7.00
	OAS-T1813	1.80	2.10	6.00	7.00

Lab Works

Fabrication 1

Posterior Palatal Vault Between 6th and 7th teeth.
In order to direct the expansion force against the buttress bones.

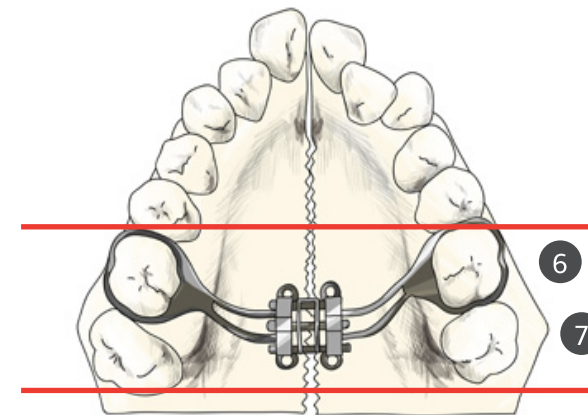

※ It is important to place 6th and 7th teeth for Bi-Cortical Engagement easily.

Posterior position

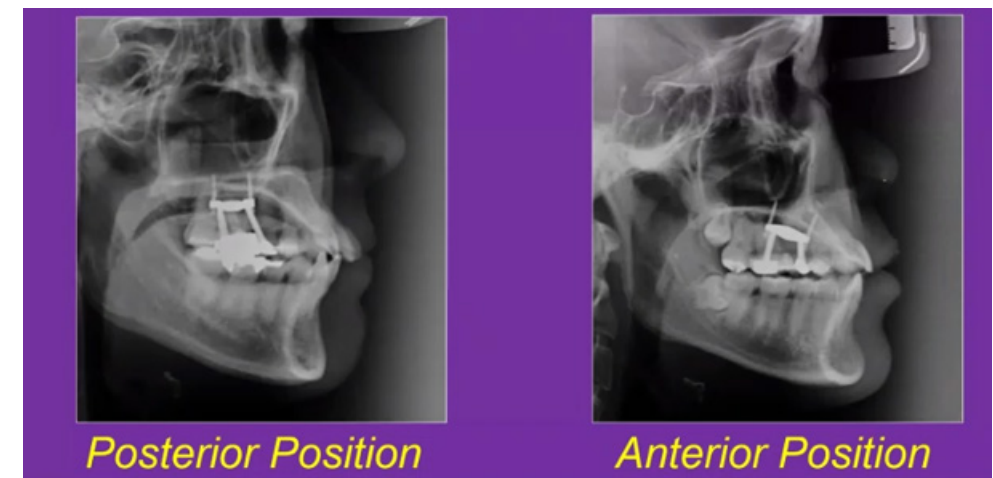

Posterior Position

Anterior Position